

CPDZ7V0-HF

RoHS Device
Halogen Free



Features

- Bi-directional ESD protection of one line.
- Reverse stand-off voltage: 7V.
- Low reverse clamping voltage.
- Low leakage current.
- Fast response time.
- JESD22-A114-B ESD rating of class 3B per human body model.
- IEC 61000-4-2 Level 4 ESD protection.

Mechanical data

- Case: DFNWB0.6x0.3-2L-B package, molded plastic.

Circuit Diagram

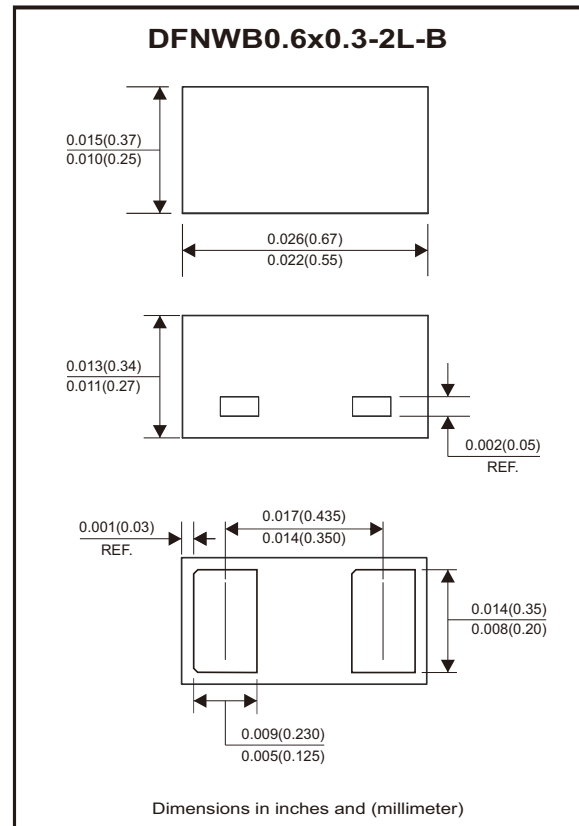

Maximum Rating (at TA=25°C unless otherwise noted)

Parameter	Symbol	Value	Unit
IEC 61000-4-2 ESD voltage air model	V _{ESD} (Note 1)	±25	kV
IEC 61000-4-2 ESD voltage contact model			
JESD22-A114-B ESD voltage per human body model			
ESD voltage machine model		±0.4	
Peak pulse power (Note 2)	P _{PP}	75	W
Peak pulse current (Note 2)	I _{PP}	5	A
Lead solder temperature - maximum (10 second duration)	T _L	260	°C
Operation junction temperature range	T _j	-40 ~ +125	°C
Storage temperature range	T _{STG}	-55 ~ +150	°C

Notes: 1. Device stressed with ten non-repetitive ESD pulses.
 2. Non-repetitive current pulse 8/20μs exponential decay waveform according to IEC 61000-4-5.

Electrical Characteristics (at TA=25°C unless otherwise noted)

Parameter	Conditions	Symbol	Min	Typ	Max	Unit
Reverse stand off voltage (Note 1)		V_{RWM}			7.0	V
Reverse leakage current	$V_{RWM} = 7V$	I_R			1	μA
Breakdown voltage	$I_T = 1mA$	$V_{(BR)}$	7.5		10.5	V
Clamping voltage (Note 2)	$I_{PP} = 5A$	V_C		15		V
Junction capacitance	$V_R = 0V, f = 1MHz$	C_J		10	15	pF

Notes: 1. Other voltages available upon request.

2. Non-repetitive current pulse 8/20 μs exponential decay waveform according to IEC 61000-4-5.

Rating and Characteristic Curves (CPDZ7V0-HF)

Fig.1 - 8/20 μs Peak Pulse Current Waveform Acc. IEC 61000-4-5

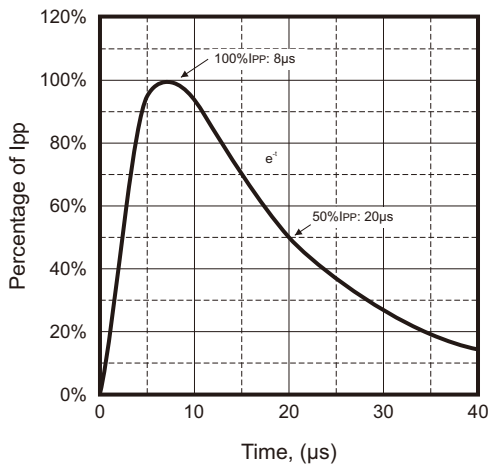

Fig.2 - Reverse Characteristics

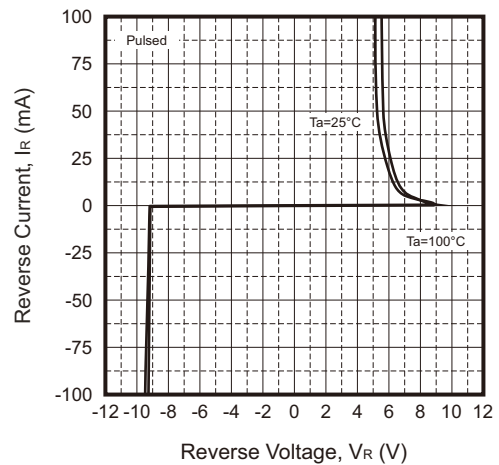

Fig.3 - Capacitance Characteristics

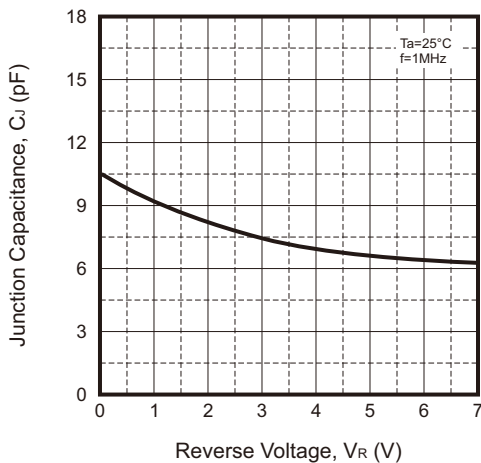
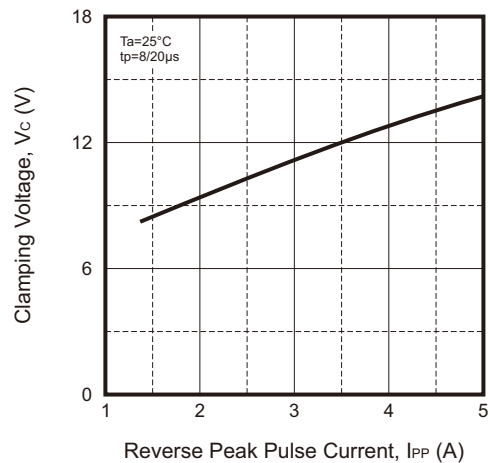
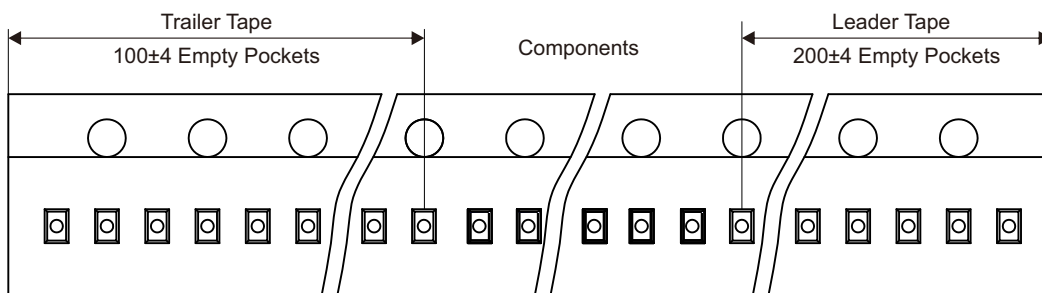
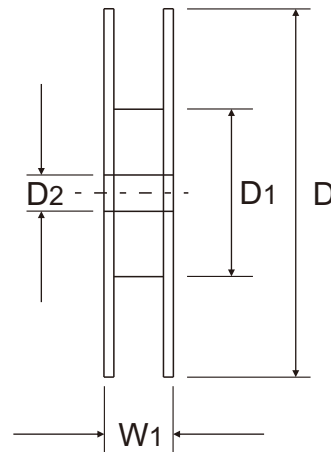
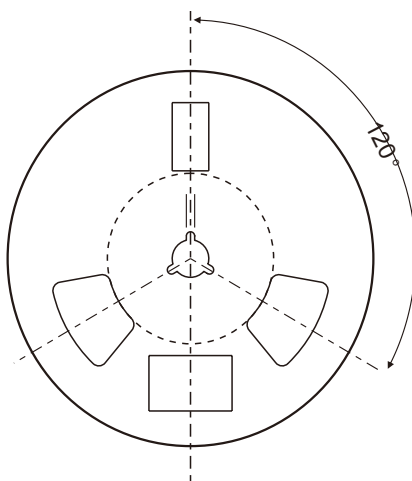
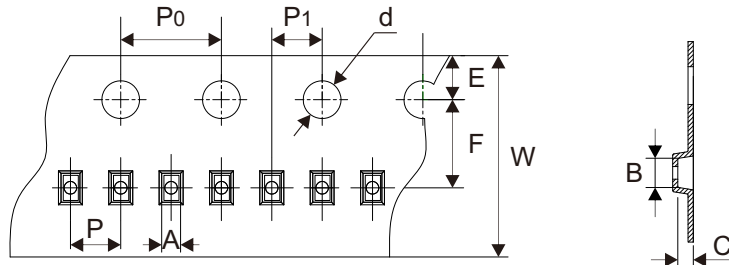

Fig.4 - VC — IPP



Reel Taping Specification



DFNWB 0.6x0.3-2L-B	SYMBOL	A	B	C	d	D	D1	D2
	(mm)	0.41 Typ	0.70 Typ	0.38 Typ	1.50 Typ	178 Typ	54.40 Typ	13.00 Typ
	(inch)	0.016 Typ	0.028 Typ	0.015 Typ	0.059 Typ	7.008 Typ	2.142 Typ	0.512 Typ

DFNWB 0.6x0.3-2L-B	SYMBOL	E	F	P	P0	P1	W	W1
	(mm)	1.75 Typ	3.50 Typ	2.00 Typ	4.00 Typ	2.00 Typ	8.00 Typ	12.30 Typ
	(inch)	0.069 Typ	0.138 Typ	0.079 Typ	0.157 Typ	0.079 Typ	0.315 Typ	0.484 Typ

Company reserves the right to improve product design , functions and reliability without notice.

REV:A

Marking Code

Part Number	Marking Code
CPDZ7V0-HF	Z



Suggested P.C.B. PAD Layout

SIZE	DFNWB0.6x0.3-2L-B	
	(mm)	(inch)
A	0.20	0.008
B	0.22	0.009
C	0.36	0.014
D	0.40	0.016

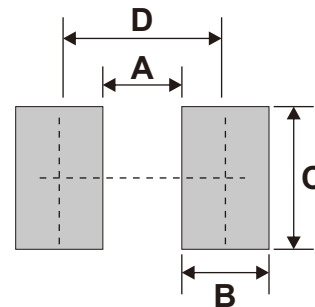

Notes: 1.The pad layout is for reference purposes only.

Standard Packaging

Case Type	REEL PACK	
	REEL (pcs)	Reel Size (inch)
DFNWB 0.6x0.3-2L-B	10,000	7